



# ARCI NEWS

www.antique-radios.org

Affiliated AWA  
Antique Wireless Association

Volume 37, Issue 3  
June, 2018



## Chicago Daily Tribune

SPORTS  
FINAL

VOLUME CCXVI—NO. 539 WASHINGTON, D. C. SATURDAY, OCTOBER 5, 1947 P. PRICE—TEN CENTS

# REDS FIRE 'MOON' INTO SKY

**POLICE CLUBS  
PUT DOWN NEW  
WARSAW RIOT**

**Spins 560 Miles Up  
at 5 Miles a Second**

## 3d Series Game Today

**Battle at Hdqrs.  
of Red Party**

**1 Hr., 35 Minutes Report Hoosiers  
Around Earth**

**DON'T WORRY ABOUT THE BEAR, OLD-TIMER, BUT  
LOOK OUT FOR TERMITES**

**Buhl, Turley  
Mound Foes  
in Milwaukee**

**HOFFA RIDES  
IN ON 3-1 VOTE  
OF TEAMSTERS**

**Sec It First**



**Today's Games**

**By BOB DALLAK  
WARSAW, Oct. 5 (AP)—**

**Following on page 4:  
MOSCOW, Oct. 5 (AP)—  
The first of the Red's an-  
nounced this morning it had  
launched satellite, the first**

**DUAL WINDS RISE?  
Chicago electronics ex-  
pert says he believes he  
found a radio signal from  
the Russian satellite, sat-**

**Starting time—2 p. m., CH  
radio time.  
Starting pitchers—**

"All the News  
That's Fit to Print"

# The New York Times

LATE CITY EDITION  
A Whole New World of News  
That's Fit to Print  
Every Day  
Newspaper, 60¢

VOL. CXXI, No. 36,761 NEW YORK, SATURDAY, OCTOBER 5, 1947 FIVE CENTS

# SOVIET FIRES EARTH SATELLITE INTO SPACE; IT IS CIRCLING THE GLOBE AT 18,000 M. P. H.; SPHERE TRACKED IN 4 CROSSINGS OVER U. S.

**HOFFA IS ELECTED  
TEAMSTERS HEAD;  
WARNS OF BATTLE**



**COURSE RECORDED  
Navy Picks Up Radio  
Signals—4 Report  
Sighting Device**



**560 MILES HIGH  
Visible With Simple  
Binoculars, Moscow  
Statement Says**

**By A. H. RABSON  
Special to the New York  
Times**  
The election of Walter P. Reuther as president of the United Brotherhood of Carpenters and Joiners of America, which is the largest of the craft unions, was announced in a statement today.  
The new president, who is 57, is a former member of the International Brotherhood of Teamsters, which is the largest of the labor unions.  
The election was held in Detroit, Michigan, and was the first since the death of the late president, Walter P. Reuther, in 1945.  
The new president, Walter P. Reuther, is a former member of the International Brotherhood of Teamsters, which is the largest of the labor unions.  
The election was held in Detroit, Michigan, and was the first since the death of the late president, Walter P. Reuther, in 1945.

**ON THREE OF VICTORY**—David Booth, center, leading head of the Transvaal Union, returns head of Francis R. Mott, center, and the British airman's president. All right is Alan, Mott, and the British airman's president.

**By WALTER REUBEN  
Special to the New York  
Times**  
The United States Navy today reported that it had received four radio signals from a satellite of the Soviet Union, which is the largest of the craft unions.  
The signals were received on October 4, 1947, and were the first since the launch of the satellite, which is the largest of the craft unions.  
The signals were received on October 4, 1947, and were the first since the launch of the satellite, which is the largest of the craft unions.  
The signals were received on October 4, 1947, and were the first since the launch of the satellite, which is the largest of the craft unions.

**Device Is 8 Times Heavier  
Than One Planned by U.S.**  
WASHINGTON, Oct. 5 (AP)—The United States

**By WALTER A. REUBEN  
Special to the New York  
Times**  
The Russian satellite of the Soviet Union, which is the largest of the craft unions, was announced in a statement today.  
The satellite, which is the largest of the craft unions, was announced in a statement today.  
The satellite, which is the largest of the craft unions, was announced in a statement today.  
The satellite, which is the largest of the craft unions, was announced in a statement today.

**REMEMBER SPUTNIK? 1957-1958  
RADIOFEST: Electronics Kits!  
HAPPY FATHER'S DAY!!!**

# UPCOMING JUNE 17, 2018 MEET

## JOINT MEET WITH 6-METER CLUB OF CHICAGO & MIDWEST CLASSIC RADIO NET HAMBOREE

### DUPAGE COUNTY FAIRGROUNDS

2015 Manchester Road, Wheaton, IL

(North of Roosevelt Road Rte. 38 and East of County Farm Road)

**June 17, 2018**  
**Gates Open 7AM**

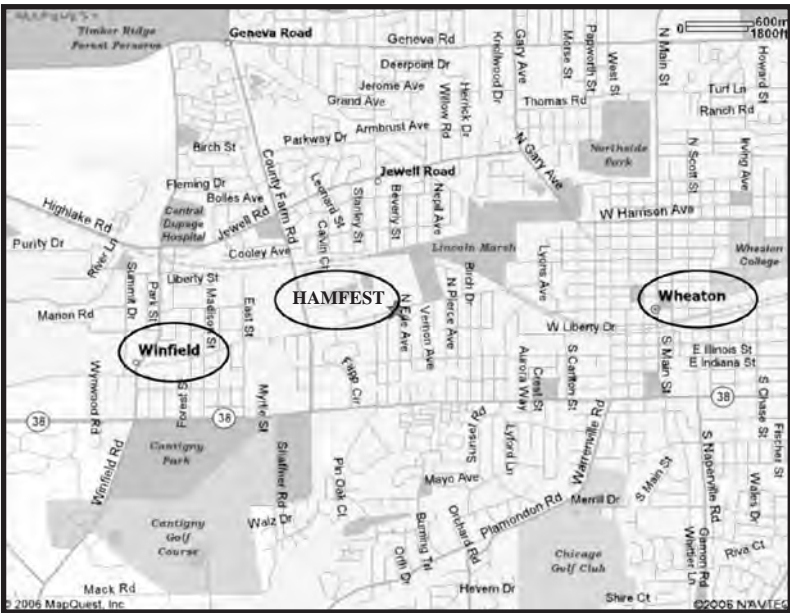

# 2018 ARCI MEET SCHEDULE

June 17, 2018	Outdoor - Gates Open 7AM Combined Meet With 6-Meter Club of Chicago	DuPage County Fairgrounds Wheaton, IL (See Advance Ticket Form & Map)
August 24-25, 2018	RADIOFEST	Medinah Shriners/Addison, IL
October 7, 2018	7AM-11AM Outdoor Swap Meet Business Mtg./Officer Election 10AM	American Legion Hall Carol Stream, IL (See Map)
December 9, 2018	7AM-11AM Indoor Swap Meet Business Meeting 10AM	American Legion Hall Carol Stream, IL (See Map)

# PRESIDENT'S MESSAGE

Spring weather in northern Illinois is a crap shoot at best. This year, after a fairly mild winter and a long-range forecast from The Weather Channel of a “warmer than normal” Spring, I let myself be lulled into imagining an April and May where I could actually go outside without having to wear an overcoat. Mother Nature, unfortunately, did not get the memo, and right on cue, sent us her cold lake effect breezes, jet streams diving down from Canada, and temperatures that have been, in April and May, anyway, colder than average.. So much for my faith in long-range forecasts.

Fortunately for ARCI, the weather cooperated, but just barely, on Sunday, April 29, the day of our annual spring meet at the American Legion in Carol Stream. Early morning temperatures stayed around the freezing mark but there was plenty of sunshine and absolutely no wind. Our members definitely took advantage of the day and showed up in full force for our first outdoor meet of the year. Club members eager to sell goods they had accumulated over the long winter bought a total of 22 outdoor spaces. There was an equally good turnout of buyers, with many really great items finding new homes. Our donation auction was once again quite large, with bargains that could only be described as incredible. A full array of test gear, old radios, fully restored chassis, speakers, and loose parts galore were among the treasures lurking in the pile. All told, the donation auction netted a cool \$374 for the club's coffers, and many happy bidders went home with great items obtained for a song. Thanks once again to Tom Kleinschmidt and Jim Novak for their great work at the auction. It is truly appreciated.

As we close in on the end of July, our attention focuses on all things *Radiofest*. Your *Radiofest 2018* staff is hard at work finalizing the details for what promises to be a memorable event. *Radiofest 2018* will be a fun-packed show that is sure to please anyone with an interest in collecting and restoring vintage radios, audio gear, and ham radio equipment. With our large swap meet, two auctions, three presentations, ham station, and awards banquet, there's sure to be something for everybody.

As most of you know by now, *Radiofest 2018* will take place in the same venue as last year, The Medinah Shriners in Addison, Illinois. You will be impressed with our location, with its large number of parking spaces, beautiful ballroom and presentation facilities, and high quality Hilton Garden Inn Hotel. In this issue of the ARCI News you will find all of the up-to-date information needed for planning on attending *Radiofest 2018*, including a registration form, equipment contest form, program information, and much more. So please take the time to read carefully through all the various parts of this newsletter pertaining to *Radiofest 2018*, and if you have any questions or comments, please don't hesitate to contact me at [smuchow@att.net](mailto:smuchow@att.net).

Now is the time to make your plans to attend our upcoming annual combined meet, hosted by the Six Meter Club of Chicago, on June 17 at the DuPage County Fairgrounds in Wheaton. This is always an enjoyable meet with great people and many interesting items for sale. The Six Meter Club members always show up with a great selection of ham gear, lots of parts, tools, test equipment, etc. And ARCI's own Swap Row puts the icing on the cake with a great selection of collectible radios, vintage hi-fi gear, phonographs, tape recorders, and many other items. There will be the usual donation auction, ham license testing, and many other associated activities. For all the details, see our dedicated article about this event, along with the Hamfest Flyer from the Six Meter Club, in this issue of the *ARCI NEWS*. I look forward to seeing all of you there and at *Radiofest 2018*.

*See You At The Next Meet,*  
Steve Muchow  
ARCI PRESIDENT

# ARCI UPDATE

The President's Column ~ All The News That's Fit To Print

## RADIOFEST VOLUNTEERS NEEDED

*Radiofest's* flea market, speaker programs, contests, auction, and displays are all made possible through the tireless efforts of a dedicated group of volunteers who have generously donated their time and talents to this wonderful event. But, we could really use some extra help from you. If you have some time available on Friday evening to help out with the auction, or on Saturday during the day to lend a hand, please consider volunteering to help us out. If you are available and would like to help us out, please contact Steve Muchow at smuchow@att.net.

Our greatest needs are in:

- *Main Auction and Parking Lot Preparation (Friday afternoon and evening).*
- *Old Equipment Contest registration.*
- *Registration.*

## RADIOFEST SPONSORSHIPS

It is not too late to participate in our ARCI Corporate Sponsorship program and our Member-Sponsor program for *Radiofest*. The *Radiofest* brochures and other *Radiofest* advertising will be printed in June. We encourage all our members to participate. *Radiofest* and other ARCI announcements directly reach almost 20,000 targeted readers with interests in historical and technical subjects. This is a great opportunity to take advantage of inexpensive advertising to a targeted audience while providing substantial assistance to our club. Please contact Steve Muchow at smuchow@att.net or Art Bilski at art@myantiqueradio.com by May 31, 2018 with any ideas or suggestions for new sponsors interested in discussing arrangements with ARCI.

## RADIOFEST SPONSOR-MEMBERS

ARCI is again offering "Sponsor-Members" status to members who are dedicated to assuring the financial strength of *Radiofest*. Members who feel they are able to contribute \$25, \$50, \$100 or more to the sponsorship fund may do so. Sponsor-Members will be listed in ARCI NEWS (but not the amount of contribution), and recognized as a group at the banquet. I am aware of a number of organizations that regularly produce events similar in size to *Radiofest*. Member-Sponsors help to provide the "emergency backing". You, as a member, are invited to help and participate as you see fit. Funds, by cash-in-person, or check identified as "Member-Sponsor Fund", should go directly to our treasurer Rudy Hecker. If you have any questions or comments, please email Steve Muchow at smuchow@att.net.



# ARCI



## MEMBERSHIP RENEWALS

**PLEASE CIRCLE YOUR MEMBERSHIP:**

<b><i>Membership Option</i></b>	<b><i>Dues</i></b>	<b><i>Benefits</i></b>
Annual Membership	\$ 25	Full benefits: <i>ARCI News</i> subscription, Fee Discounts At Events, Seller Privileges at ARCI Events.
Spousal Annual Membership	\$ 10	Discounts at Events.
Student Annual Membership	\$ 5	Must Be 18 or Under, Full Benefits.
Lifetime Membership	\$340	Full Membership Benefits For Life (non-transferable).

**MAKE YOUR CHECK PAYABLE TO ARCI AND SEND TO:**

Antique Radio Club of Illinois  
P.O. Box 1139  
LaGrange Park, Illinois 60526

**EMAIL DELIVERY OF ARCI NEWS? YES OR NO (CIRCLE ONE)**

**PRINT DELIVERY OF ARCI NEWS? YES OR NO (CIRCLE ONE)**

Name: \_\_\_\_\_

\_\_\_\_\_

Spouse: \_\_\_\_\_

\_\_\_\_\_

Address: \_\_\_\_\_

\_\_\_\_\_

City: \_\_\_\_\_ State: \_\_\_\_\_ Zip Code: \_\_\_\_\_

\_\_\_\_\_

Home Phone: \_\_\_\_\_ Application Date: \_\_\_\_\_

Email: \_\_\_\_\_

Emergency Contact Name: \_\_\_\_\_ Phone: \_\_\_\_\_



## **I WANT YOU TO VOLUNTEER WITH ARCI !!**

*We Need Your Help To Run Your Club!!*

- ARCI News – Authors, Contributors
  - Radiofest – Volunteers
  - Local Meets – Volunteers
  - Radiofest Staff – Auction, Registration
  - Radiofest Hospitality Tent – Donors, Staff
- Earn your stripes today!**

*Please Contact Your Board Members & Club Officers  
Steve Muchow, ARCI President  
[smuchow@att.net](mailto:smuchow@att.net)*

## **REGISTER EARLY FOR JUNE HAMFEST COMBINED MEET WITH SIX METER CLUB**

The June ARCI swap meet will be a joint event with the Six Meter Club of Chicago on Sunday, June 17, 2018 at the DuPage County Fairgrounds, 2015 Manchester Rd., in Wheaton - just a bit south and west of our ARCI meets at the American Legion in Carol Stream. Last year more than 1,200 radio enthusiasts and hams from 16 states and with visitors from Canada and Mexico participated in the giant flea market and other events, including many ARCI members who were able to park in a special area designated as ARCI Swap Row.

We will have displays from AMSAT, ARRL, NWS/Skywarn and dealer displays. And, the Midwest Classic Radio Net's Hamboree will be back with us again. MCRN is a gathering of hams that operate "boat anchor" equipment on a weekly 3885 kHz AM net.



Everyone **MUST** have a Hamfest ticket to attend. Tickets are still only \$6 in advance, or \$8 at the gate. There is no charge for outdoor flea market space - please see the registration form for information. Jim Novak will have advance tickets at our April 29th ARCI meet. As usual, ARCI will have its donation auction at 10 am along with the 50-50 drawing. In addition, if you deposit your Hamfest ticket stubs in the drum near the stage in Building 2, you have a chance to win many other prizes including \$300, \$200 and \$100 cash.

Indoor flea market sellers and commercial dealers will be in Buildings 2, 3 and 4 with the outdoor flea market to the east of the Exhibition Hall building and extending north along the east side of the fairgrounds. All traffic will enter and exit through gate S-7 located east of the main exhibition hall. For ham operators, station K9ONA will be on the air, serving as a talk-in station on two meter FM, 146.52 simplex and through the 146.37/97 repeater (107.2 Hz tone). Food, coffee and soda will be available from the Romeoville Knights of Columbus.

For anyone wishing to take an FCC Amateur Radio license exam, testing will be held from 9 to 11 am.

The Hamfest opens to the general public at 7 am (buildings at 8 am), but ARCI members who are willing to help direct traffic for parking – we will need help keeping ARCI Swap Row open for members – can enter at 6 a.m. providing you have an advance ticket and can show positive ARCI ID (your current membership card). You can then pick out your favorite flea market parking space and lend a hand for a few minutes when the gates open at 7. We could also use some help Saturday afternoon after 2 pm setting up signs, the PA system, tables, etc.

Anyone who can help out or who needs advance tickets or more information can call Jim Novak at 708-420-9571 or email [WA9FIH@aol.com](mailto:WA9FIH@aol.com).

## HAM RADIO AND ELECTRONIC FLEA MARKET

Also featuring Antique and Vintage Radios - now Bigger and Better than ever!

### SIX METER CLUB OF CHICAGO

### 61<sup>ST</sup> ANNUAL HAMFEST

and *Antique Radio Club of Illinois* Swap Meet  
plus Midwest Classic Radio Net Hamboree!

Sunday, June 17, 2018

DuPage County Fairgrounds, Wheaton, Illinois

2015 Manchester Road (North of Roosevelt Rd., Rte. 38), East of County Farm Rd.

GPS COORDINATES: N41.866667, W-88.132989

**GATES AND FLEA MARKET OPEN 7 A.M. BUILDINGS OPEN TO PUBLIC 8 A.M.**

- All Weather, Large Outdoor Flea Market AND More than 20,000 square feet of indoor selling space for those who prefer to be inside
  - AMSAT, ARRL, Skywarn and Dealer Displays
  - Good Food and Refreshments at Reasonable Prices
  - Free Parking - no extra charge for outdoor space
  - Donation Auction at 11 a.m. - Proceeds to ARCI (Radios, Test Eqp., Parts Only - NO PCs)
  - Overnight RV Parking w/110V hookup - must Register in Advance!
  - 1<sup>st</sup> - \$300, 2<sup>nd</sup> - \$200, 3<sup>rd</sup> - \$100 and many other door prizes awarded at Noon
  - TICKETS: Advance \$6.00; At Gate \$8.00 - Use form below to order advance tickets.
  - TALKIN: K9ONA 146.52, K9ONA/R 146.37/97 (107.2)
  - **ALL TRAFFIC ENTER GATE 5-7 EAST OF BUILDING**
- INFORMATION: E-Mail [WDGJK@aol.net](mailto:WDGJK@aol.net) or call our 24 Hour InfoLine - (708)442-4961



ARRL VEC License Exams 9 a.m. \$15.00 fee  
ARRL Card Checking will also be available

#### VISIT OUR WEB SITES:

SIX METER CLUB OF CHICAGO: [www.k9ona.com](http://www.k9ona.com)

ANTIQUA RADIO CLUB OF ILLINOIS: [www.antiquradios.org](http://www.antiquradios.org)

MIDWEST CLASSIC RADIO NET: [www.mcrn3885.net](http://www.mcrn3885.net)

**PLEASE NOTE: ABSOLUTELY NO ALCOHOLIC BEVERAGES PERMITTED**

**NO SALE OF FOOD OR BEVERAGES IN FLEA MARKET - All Sellers Responsible for Cleanup of Their Spaces!**

Return with check payable to "Six Meter Club of Chicago" and **Self-Addressed, Stamped Envelope to:**  
Six Meter Club of Chicago, 3532 Raymond Avenue, Brookfield IL 60513-1204 **no later than June 1, 2018.**

Please send Tickets/Reservations as follows:

ADVANCE TICKETS (every attendee age 12 and over)

# \_\_\_\_\_ @ \$6.00 ea. = \$ \_\_\_\_\_

COMMERCIAL DEALER TABLES 8ft. w/110V

# \_\_\_\_\_ @ \$12.00 ea. = \$ \_\_\_\_\_

NOTE: No extra charge for tables w/110V as available, first come first served!

OVERNIGHT RV PARKING FAIRGROUNDS FEE (includes 110V) # \_\_\_\_\_ @ \$45.00 ea. = \$ \_\_\_\_\_

PLEASE PRINT:

Name: \_\_\_\_\_ E-Mail: \_\_\_\_\_

Address: \_\_\_\_\_ Phone: ( \_\_\_\_\_ ) \_\_\_\_\_ - \_\_\_\_\_

City: \_\_\_\_\_ State: \_\_\_\_\_ ZIP: \_\_\_\_\_



# ANTIQUE PHONOGRAPH & MUSIC BOX SHOW MARKS 43rd YEAR

Donley is hosting its annual Phonograph and Music Box Show in Union, Illinois on June 9-10. This collector show specializes in phonographs, music boxes and automata but has cross-over with radio and electronics collectors. Historically, vintage radios have been well represented. The show has a large public following and takes place in space adjacent to Donley's Wild West Village and the restaurant. Bring the entire family and your children/grandchildren to enjoy a day of collecting and entertainment in the old west. See the special centerfold pull out for more information.



The show is open to the public on Saturday June 9th and on Sunday June 10th. Admission to the show is \$9.00 and is good for both days. A special preview admission of \$40 per person is available for those wishing to mingle with the dealers during the show setup on Friday June 8th.

Donley's Wild West Town is located 45 minutes Northwest of O'Hare airport just off Interstate 90, at the intersection of Route 20 & S. Union Road, 2 miles south of the village of Union, in McHenry County Illinois. GPS 8512 S. Union Rd. Union, IL 60180. For further information call 815-790-9436 or see [www.WildWestTown.com](http://www.WildWestTown.com).





*Nothing else even comes close*

the 43rd annual

# Vintage Music Show

Saturday & Sunday June 9th & 10th 2018

## Union, Illinois

Over 100 Quality Dealers Featuring

- Cylinder & Disc Phonographs
- Cylinder & Disc Music Boxes
- Rare Coin - Op Phonographs
- 78 rpm & Cylinder Records
- Roller Organs & Vintage Radios
- Vintage Advertising
- Hard to find Parts
- Qualified Service for your Machines
- Early Invention & Technology Items

### SHOW HOURS

Saturday June 9th 9 am to 5 pm

Sunday June 10th 10 am to 3 pm

Setup Friday June 8th 8 am to 4 pm

### GENERAL ADMISSION

\$9 at the door good for both Sat & Sun

### PREVIEW ADMISSION

\$40 Per person good on Friday during setup and Saturday & Sunday also

always held at

### Wild West Town

8512 S. Union Rd. Union, IL 60180

Located 45 min NW of Chicago O'Hare Airport

just off I-90 at route 20

[www.WildWestTown.com](http://www.WildWestTown.com)



for pictures of the 2017 Show  
visit [www.WildWestTown.com](http://www.WildWestTown.com)



for Dealer information contact

Mike Donley 815.790.9436

email [mdonley@dls.net](mailto:mdonley@dls.net)

# RADIOFEST 2018 PLANNING UPDATE

By Steve Muchow, ARCI President

**\*\* NEW DATES -- Radiofest 2018 -- NEW DATES \*\***

**Friday August 24 - Saturday August 25**  
**Medinah Shriners**  
**550 N. Shriners Drive**  
**Addison, IL 60101**

*Radiofest 2018 will take place at the end of August due to conflicts at the Medinah Shriners. We hope to return to an early August schedule in 2019.*

Reserve the dates of Aug. 24-25. Building on the tremendous success of *Radiofest 2017*, we are enthusiastically putting together a two-day schedule of events that will be very similar to last year, except for a few minor changes due, in part, to the elimination of Sunday morning. Be sure to reserve the dates shown above on your calendar for *Radiofest 2018!*

**LOCATION:** We will return to the **Medinah Shriners in Addison, Illinois**. This new, modern, upscale facility is across from a **Hilton Garden Inn**. The Medinah Shriners is located at the junction of I-355 and Army Trail Road in Addison. This is a very convenient location that can be easily accessed from all directions within the entire Chicago area. See the map below for location details.





**HOTEL:** Our official hotel for *Radiofest 2018* is the Hilton Garden Inn, located directly adjacent to the Medinah Shriners complex, and a very short walk from the banquet facilities and parking lots. Medinah Shriners and Hilton Garden Inn are completely independent entities, but they coordinate closely on events. Our contact at Shriners again helped us negotiate a really great price with the hotel at a rate of \$95 per night—same as 2017. This is a really nice hotel at a great price. You will not be disappointed!

Reservations for the hotel are now open! We have secured a block of rooms at the Hilton Garden Inn and reservations for the hotel are now open! You can go to the online reservation system, which has been set up exclusively for *Radiofest* reservations, at this web site:

[http://hiltongardeninn.hilton.com/en/gi/groups/personalized/C/CHIAHGI-RAD18-20180823/index.jhtml?WT.mc\\_id=POG](http://hiltongardeninn.hilton.com/en/gi/groups/personalized/C/CHIAHGI-RAD18-20180823/index.jhtml?WT.mc_id=POG)

Or, you can call the hotel at: 630-691-0500. Mention *Radiofest* to the friendly reservation agent to get the special discount rate.

<p><b>RADIOFEST</b>  <b>Medinah Shriners</b>          550 Shriners Drive          Addison, IL 60101          (630)-458-0200</p>	<p><b>HOTEL</b>  <b>Hilton Garden Inn Addison</b>          551 N Swift Road          Addison, IL 60101  <a href="http://hiltongardeninn3.hilton.com">hiltongardeninn3.hilton.com</a>          (630) 691-0500</p>
---	--

**SCHEDULE:** Just like 2017, we will start the action with our Friday night auction, followed on Saturday morning by the swap meet through mid-afternoon. The swap meet will again be located in its own large parking lot at the west end of the facility. There will be plenty of seller spaces available with lots of room between rows for maneuvering a small truck or a vehicle with a trailer. The sellers' lot is also totally out of the main traffic flow, which is good for those walking around the swap meet. The pavement will be marked with parking spaces and continues to be in excellent physical condition. Directly adjacent to the sellers' lot is the main parking lot, with over 170 spaces available for buyers and visitors. It is an easy walk from one lot to the other, with plenty of spaces available. This parking layout is well-suited for *Radiofest!*

**AUCTION:** The opening night auction will be in the Medinah Crescent Ballroom, with overflow space in the adjacent Medinah Music Room. The large quantity and excellent quality of items available in the auction make this a "must attend" event. You never know what you will find here, including rare and highly collectible items. Jim Sargent from VRPS is returning to co-manage the auction.

**PROGRAMS:** Our speakers' programs, contest, and display will occur throughout the day on Saturday, followed by the Carl & Carolyn Knipfel banquet on Saturday night. *Radiofest 2018* speakers' programs will feature three sessions, with a break during the noon hour. Programs will include topics on broadcasting program material through your antique radio, mechanical television, and the Bill Ross Ham Forum with a focus on Heathkits and the Heath Company.

**DISPLAY:** This year, *Radiofest 2018* will commemorate Electronic Kits. Chances are if you have been around antique radios for a while, you have either built or used a piece of equipment that started out as a kit. Remember names like Heathkit, Allied Radio/Knight Kit and EICO? These are the big names, but there were and continue to be other companies offering kits for radios and electronics equipment. Do you have nice examples of built or unbuilt kits you might be interested in sharing in the display? Along with the kit, any related documentation such as the instruction manual, advertising literature and even the original box would enhance the display. Watch future issues of ARCI NEWS and the ARCI website for additional information.

**CONTEST:** This year's contest categories will include the electronic kits brought in for display and other categories to be announced in the future.

**APPRAISALS:** We will also have our popular appraisal tent and the outdoor ham station with special ARCI club call letters WA9RCI.

**DONATIONS:** The usual donation auction will be held late in the afternoon on Saturday. Keep in mind that you may purchase donated items throughout the day without having to wait for the actual donation auction. Either way, your purchase will likely be a bargain! We are always looking for suggestions on ways to improve it. If you have a good idea, please contact Steve Muchow at smuchow@att.net.

**BANQUET:** Banquet tickets are priced at \$40 per person. The Banquet Buffet menu will be: Tossed salad with three dressings, Roast sirloin of beef with Bordelaise sauce, Penne pasta in Marinara sauce, Baked herbed chicken breast, Twice baked potato, Broccoli, Cauliflower, Assorted fresh fruit tray, Vanilla ice cream with chocolate topping. Beverage choice will be coffee, hot or iced tea. The entertainment selection for the Saturday Night banquet is underway and will be announced in future editions of ARCI NEWS and on the ARCI website, when available.

**5 CLUBS:** Once again, we will team up with the Wisconsin Antique Radio Club, Inc. (WARCI), the Vintage Radio and Phonograph Society (VRPS) of Dallas, Texas and the Antique Wireless Association (AWA). *Radiofest* will be co-sponsored by four important clubs, making it truly THE national event of the summer!

**UPDATES:** Watch for additional *Radiofest 2018* information in future editions of the ARCI NEWS, *Radiofest* mailings and our ARCI web site [www.antique-radios.org](http://www.antique-radios.org). With our wonderful location and our dedicated team of ARCI volunteers, you can understand why we are enthusiastic as we plan for our largest event. So, mark your calendars and start making plans to attend! Please feel free to contact me at [smuchow@att.net](mailto:smuchow@att.net) should you have any questions, comments, or suggestions.



## ***RADIOFEST 2018 FEES***

***Selling Spaces*** – 1st \$45.00 Pre-registration, \$50.00 Onsite; Additional Spaces  
\$25.00 Pre-registration, \$35.00 Onsite

***Banquet*** – \$40.00 each

***Entertainment: Eddie Korosa Jr. Band***

***6' TABLE RENTALS*** – \$15.00 each

*Only through pre-registration*

## ***RADIOFEST 2018 PRELIMINARY SCHEDULE***

### **FRIDAY (8/24)**

Pre-Registration Available After 3pm  
Main Auction at 6:30pm (Crescent Ballroom)

### **SATURDAY (8/25)**

7am Registration / *Radiofest* Opens  
Flea Market 7am - 3pm (West Lot)  
Special Event Ham Radio Station - All Day  
Educational Programs (Room B)  
Old Equipment Contest (Music Room)  
Donation Sale - 7am till 3pm  
Donation Auction at 3:30pm  
Banquet & Entertainment (Crescent Ballroom)

## ***RADIOFEST 2018 PRELIMINARY PROGRAMS (As of June)***

***11am***

***Bill Ross Memorial Ham Radio Forum***

***Topic: History of Heathkit***

Harry Blesy, Bob Drake, Ron Grams

Guest speakers: Erich Brueschke & Michael Mack

\*\*\*\*

***1pm***

***Mechanical Scanning System Developed by the  
Chicago Television & Research Laboratory***

Ralph Taylor

\*\*\*\*

***2pm***

***Vintage Radio Programming on your Antique Radio***

Pete Nauseda

**RADIOFEST 2018  
SPECIAL EQUIPMENT DISPLAY**

**ELECTRONIC KITS**

*Commemorate the history and evolution of radio and electronics kits.  
If you have any items you wish to display,  
please fill out the form in this issue or contact the organizers*

**RADIOFEST 2018 CONTEST CATEGORIES**

*With Awards For:*

*Dr. and Mrs. Ralph Muchow "Best Of Show" Award*

*People's Choice Award*

*Chairman's Trophy; Best Historical Display*

*1<sup>st</sup>, 2<sup>nd</sup>, 3<sup>rd</sup> Per Category*

*Radios and Apparatus Pre-1930*

*Radios/TVs Thru WWII (Up to 1945)*

*Radios/TVs Post WWII (After 1945)*

*Advertising / Premiums*

*Speakers*

*Electronic Kits*

*Open*

**RADIOFEST 2018 BANQUET ENTERTAINMENT**

**Eddie Korosa Jr. Band**





# RADIOFEST

**August 24 and August 25th, 2018**



**Event:** Medinah Shriners ~ 550 N. Shriners Dr. Addison, IL 60101

**Hotel:** Hilton Garden Inn ~ 551 North Swift Rd., Addison, IL 60101  
**Hotel Reservations:** (630) 691-0500

*All hotel reservations must be made directly with the Hilton Garden Inn  
Discounted Hotel rates for ARCI members begin at \$95.00*

**RADIOFEST** Will Feature a Large Radio Swap Meet, Radio Contest, Informational Presentations, Appraisal Tent & Auctions. Our Banquet also returns with great food, entertainment, and awards. Events and Schedule subject to change. Watch our website for updates at: [www.antique-radio.org](http://www.antique-radio.org)

*All sellers must be members of **ARCI** - NO ADMISSION CHARGE FOR NON-SELLERS*

**ARCI Membership (\$25.00)**

(If not currently a member) \$ \_\_\_\_\_

**First Selling Space**

\$45.00 Pre-Registration

\$50.00 On Site Registration

**Additional Spaces**

\$25.00 Each Pre-Registration

\$35.00 Each On Site Registration

# \_\_\_\_\_ times \$25.00 or \$35.00 = \$ \_\_\_\_\_

**Table Rentals-Pre-registration only**

6 ft. # \_\_\_\_\_ times \$15.00 = \$ \_\_\_\_\_

Free parking for attendees in the lot directly adjacent to the swap meet lot. If you are reserving a paid space in the swap meet lot, for parking purposes only, please check here \_\_\_\_\_

**Banquet (Buffet Style) and Show**

Buffet Selection:

Beef, Chicken, or Pasta served with Garden Salad, 2 Sides, Fresh Fruit, Coffee, Regular or Iced Tea

# \_\_\_\_\_ Attending times \$40.00 = \$ \_\_\_\_\_

TOTAL OF ALL \$ \_\_\_\_\_

Names for banquet name tags \_\_\_\_\_

NAME: \_\_\_\_\_

ADDRESS: \_\_\_\_\_

CITY \_\_\_\_\_ STATE \_\_\_\_\_ ZIP \_\_\_\_\_

PHONE # DAY: \_\_\_\_\_ EVENING: \_\_\_\_\_

E-MAIL: \_\_\_\_\_ APPLICATION DATE: \_\_\_\_\_

EMERGENCY CONTACT NAME: \_\_\_\_\_ PHONE: \_\_\_\_\_

Please list any special requests or comments below

\_\_\_\_\_  
\_\_\_\_\_  
\_\_\_\_\_  
\_\_\_\_\_  
\_\_\_\_\_

In order to receive confirmation of your registration and selling space assignment from ARCI by mail, we must receive your registration form on or before July 1, 2018. All sellers must check-in at the Registration Area upon arrival at Radiofest, to receive their parking permits. All selling and parking spaces in the swap meet lot will be assigned by ARCI.

Make check payable to ARCI and mail to: ARCI c/o Edward & Judy Huether; 1039 Troost Ave.; Forest Park, IL. 60130

Have Questions or need more information? Check our website at [www.antique-radios.org](http://www.antique-radios.org) or send e-mail to [clubinfo@antique-radios.org](mailto:clubinfo@antique-radios.org)

**FOR OFFICIAL USE ONLY**

Date Received \_\_\_\_\_ Registration # \_\_\_\_\_ Check # \_\_\_\_\_ Spaces \_\_\_\_\_

# SPECIAL RADIOFEST DISPLAY

## ELECTRONICS KITS

This year we are celebrating radio and electronic kits. We invite you to participate in our special display theme for *Radiofest 2018*. ARCI members are invited to bring one or several pieces of equipment for display, but **MUST** preregister to avoid duplication of entries in the limited space available.

We will have a display of any and all radio and electronics kit and kit-related items. We are looking for your contributions such as but not limited to:

- Early (1940s to 1960s) tube or transistor radios
- Kits (built and unbuilt) from well-known and lesser-known suppliers
- Test equipment
- Hi-Fi and Stereo
- Unusual product categories
- Related items such as original boxes that housed the kit
- Any original documents such as building instructions and advertising items.

We would like to feature any items with newspaper or magazine articles and original equipment instructions, documentation and photos. The display is not limited to commercially produced items.

Please submit the *RADIOFEST 2018* SPECIAL DISPLAY REGISTRATION FORM which will be available at the April meet and is also downloadable from our ARCI website. Submit it to Jeff Aulik or Barry Janov no later than June 15 for consideration by the committee. Our intent is to notify each applicant no later than July 4 regarding which items will be accepted for display.

NOTE: The Special Display is a special feature of *Radiofest* that operates in addition to the contest room. We invite our members to participate in both venues. Please email Jeff Aulik at [akent36@comcast.net](mailto:akent36@comcast.net) or Barry Janov at [marconifon@gmail.com](mailto:marconifon@gmail.com) if you would like to participate





## RADIOFEST 2018



**SPECIAL DISPLAY AUGUST 25, 2018**

### **REGISTRATION FORM APPLICATION DEADLINE JUNE 15, 2018**

**\*\*ELECTRONICS KITS\*\***

AFTER REVIEWING THE CATEGORIES LISTED IN THE DISPLAY ANNOUNCEMENT, PLEASE LIST EACH ITEM THAT YOU WISH TO DISPLAY WITH BRIEF DESCRIPTIONS. WE INTEND TO HAVE THE DISPLAY ROOM OPEN FOR VISITORS BY SATURDAY AFTERNOON AT APPROXIMATELY 3PM WITH TAKEDOWN AFTER 10PM. SECURITY WILL BE PRESENT AND THE ROOM WILL BE LOCKED DURING HOURS WHEN IT IS CLOSED TO PUBLIC VIEWING. WE ALSO NEED VOLUNTEERS WHO CAN ACT AS "DOCENTS" TO SPEND 30-60 MINUTES IN THE DISPLAY AREA ANSWERING QUESTIONS ABOUT THE DISPLAY.

ITEM(S) YOU WOULD LIKE TO DISPLAY:

NAME \_\_\_\_\_ CALL SIGN \_\_\_\_\_

ADDRESS \_\_\_\_\_  
\_\_\_\_\_

PHONE (\_\_\_\_) \_\_\_\_\_ - \_\_\_\_\_ EMAIL \_\_\_\_\_

SERVE AS DOCENT? (CIRCLE ONE) YES NO HOURS \_\_\_\_\_

**FOR INFORMATION PLEASE CONTACT BARRY JANOV AT: [marconifon@gmail.com](mailto:marconifon@gmail.com) OR  
JEFF AULIK, 1708 PARKVIEW AVE, ROCKFORD, IL, 61107 AT: [akent36@comcast.net](mailto:akent36@comcast.net)**



# Radiofest 2018

**August 24-25**

*Friday – Saturday*

**Medinah Shriners**

550 Shriners Dr. (I-355 & Army Trail Rd.)  
Addison, IL 60101



## COMMEMORATING ELECTRONIC KITS

### FRIDAY

- Setup Day (**NO SALES**)
- Main Auction 6:30pm in the Crescent Ballroom
- Food Services Available
- Seller's Packets Available After 5pm

### SATURDAY

- 7am *Radiofest* Opens
- Registration open
- Flea Market open All Day
- Educational Programs
- Ham Radio Ops All Day
- Food Services Available

### SPECIAL EXHIBIT *Electronic Kits*

- Radio / TV / Hi-Fi
- Test Equipment
- Memorabilia
- Advertising

### EQUIPMENT CONTEST

- 1 Radios/Apparatus Pre-1930
- 2 Radios/TVs Thru WWII (Up to 1945)
- 3 Radios/TVs Post WWII (After 1945)
- 4 Advertising/Premiums
- 5 Speakers
- 6 Electronic Kits
- 7 Open Category

### SATURDAY NIGHT BANQUET

Dinner, Annual Recognition & Contest Awards

### ENTERTAINMENT:

*Eddie Korosa Jr. Band*



See *Radiofest* registration form for further information

### SATURDAY PROGRAMS

**Bill Ross Memorial Ham Radio Forum** – History of Heathkit – *Joint presentation by Harry Blesy, Bob Drake, & Ron Grams with guest speakers Erich Brueschke & Michael Mack*

**Mechanical Scanning System: Chicago Television & Research Laboratory** – *Ralph Taylor*

**Vintage Radio Programming on your Antique Radio** – *Pete Nauseda*

### IMPORTANT INFORMATION

**ARCI Registration Form:** <http://www.antique-radios.org>. **Pre-Registration Deadline:** July 1.

**Hotel Reservations:** Hilton Garden Inn 1-630-691-0500. Ask for ARCI room rates \$95 per night.

**Seller Fees:** 1st space: \$45 pre-registration/\$50 onsite. Additional spaces: \$25 pre-reg/\$35 onsite. Banquet tickets: \$40/person. **TABLE RENTALS:** 6' (\$15) (pre-registration only). No charge for general admission. Membership required for attending programs.

**Questions?** Email: [clubinfo@antique-radios.org](mailto:clubinfo@antique-radios.org), or visit: [www.antique-radios.org](http://www.antique-radios.org).

## MAIN AUCTION ON FRIDAY NIGHT

The Main Auction will take place on Friday evening in the Crescent Ballroom and adjoining Music Room, with a starting time of 6:30 PM. Check-in for the Main Auction will open no later than 3:30pm. We anticipate another very busy auction this year, so we suggest you allow as much time as possible to register and get your items in place. Sellers will be able to unload their items through the front entrance of the Medinah facility until 6:00PM on Friday. The Crescent Ballroom is easily accessible from the front entrance, but we strongly suggest you bring your own hand truck or rolling cart with you, if you are bringing heavy or oversized items. Ample parking for buyers and sellers will be available in the lot directly in front of the facility.

This year, ARCI will again partner with the Vintage Radio Phonograph Society (VRPS) from Irving Texas to run the main auction, and Nick Tillich, president of the Wisconsin Antique Radio Club, Inc. (WARCI) will handle the computers and processing. Jim Sargent, VRPS member and professional auctioneer, has again generously contributed his time and skills to call the auction, and will be assisted by our team of volunteers. John Stone will be managing and coordinating the auction.

Fees are unchanged from last year: \$7 per item for sellers (\$10 for non-members), bidding cards at \$3 each (\$5 for non-members) and a 10% buyer's premium applies. There is a limit of 10 lots per person

The auction format will be the same as last year, allowing sellers to continue to state a confidential reserve. We plan to have our trusty team of volunteers and assistants in place to make the check-in/check-out process as smooth as possible. We will do everything to make the check-in/check-out process as smooth and quick as possible, but we know that sometimes the lines can get a little long during these periods. We very much appreciate your continued patience and courtesy during this process.

Our *Radiofest* main auction has gained a well-deserved reputation for having some of the most unique, high quality goods, and we expect much the same for this year. We have been informed that there will be some very interesting items placed in this year's auction, including some rare and collectible vintage hi-fi equipment! So, please plan on making this part of your *Radiofest* experience. It is great fun, and you may just find that rare treasure you've been looking for! There will food and refreshments available for purchase throughout the duration of the auction.

Please contact John Stone at [jmsent2@comcast.net](mailto:jmsent2@comcast.net) if you have any questions or comments regarding the auction.

## SATURDAY NIGHT BANQUET

The Crescent Ballroom will be the site of the annual "Carl and Carolyn Knipfel Banquet." The entertainment this year will feature **The Eddie Korosa Jr. Band**, an award-winning group playing all types of music. Banquet tickets are priced at \$40 per person. The Banquet Buffet menu will be: Tossed salad with three dressings, Roast sirloin of beef with Bordelaise sauce, Penne pasta in Marinara sauce, Baked herbed chicken breast, Twice baked potato, Broccoli, Cauliflower, Assorted fresh fruit tray, Vanilla ice cream with chocolate topping. Beverage choice will be coffee, hot or iced tea. So come prepared for a great meal, wonderful entertainment, and an all around good time with your ARCI friends!



*Radiofest 2018 Banquet Entertainment – Eddie Karosa Jr. Band. Radiofest 2018 Banquet*

## **PLANS UNDERWAY FOR VINTAGE HAM STATION AT RADIOFEST**

Jim Novak, WA9FIH is currently planning our vintage amateur radio station for *Radiofest*. We typically set up stations capable of AM, SSB and CW operation on the 75/80, 40 and 20 meter ham bands, as well as two meter FM, using gear that dates from the vacuum tube era into early solid state units. A Special Event Station will be on the air all day Saturday until teardown.

Last year, equipment and antennas were provided by Jim Novak WA9FIH, Ron Grams, WB9IMR, and Steve Muchow, K9AHS. If you have a piece of equipment you would like to bring, either for display or to put on the air, or would like to be involved with operating the station and/or setting up or taking down antennas, please contact Jim at 708-420-9571 or WA9FIH@aol.com. We will be installing antennas and checking out equipment on Thursday afternoon. Thanks!

## FREE SELLERS' RAFFLE

To thank our sellers for participating, we will offer a free Sellers' Raffle scheduled on Saturday. A number of great items will be raffled off. Sellers must be in attendance to win.

## DONATION AUCTION

The donation auction, everyone's favorite place for real bargains, is scheduled for Saturday afternoon. Items donated to the club will be sold at either the Donation Sale Table or the Saturday Donation Auction at the discretion of the auctioneer. We encourage everyone to walk the show regularly to see what becomes available. Questions can be addressed directly to Tom Kleinschmidt at tomkleinschmidt@comcast.net.

## **NEWS FROM THE HAMSHACK**

**By: Jim Novak, WA9FIH**

### **NOVICE TWIN TRANSMITTERS: JOHNSON VIKING ADVENTURER AND KNIGHT T-50**

A recent e-mail conversation with our Ham Radio station trustee Ron Grams, WB9IMR, jogged my memory about a couple of 1950s era transmitters that were aimed at the market for Novice Class licensees, beginners in amateur radio, who were limited to using Morse code only and required to upgrade to a higher class FCC license within a year.



*Johnson Viking Adventurer.*

E.F. Johnson, based in Waseca, Minnesota, offered their Viking Adventurer transmitter as a kit from the mid-1950s until the early 1960s. It was housed in a nice looking maroon and gray cabinet about 7-1/2" x 10-1/2" x 8". It covered the amateur 10, 11, 15, 20, 40 and 80 Meter bands (11 Meters had not been reassigned by the FCC to Citizens Band (CB) at that point), and used a 6AG7 oscillator and 807 power amplifier tube, plus a 5U4G rectifier. The kit sold for \$54.95. Plate input power was

50 Watts, well within the FCC-prescribed 75 Watt Novice limit. Crystal control was required for Novices back then, but Johnson also had a VFO available that could be used when the operator upgraded to General Class. A plug-in screen modulator kit using a 12AU7 and 12AX7 was also available for \$12.25.

## FREE SELLERS' RAFFLE

To thank our sellers for participating, we will offer a free Sellers' Raffle scheduled on Saturday. A number of great items will be raffled off. Sellers must be in attendance to win.

## DONATION AUCTION

The donation auction, everyone's favorite place for real bargains, is scheduled for Saturday afternoon. Items donated to the club will be sold at either the Donation Sale Table or the Saturday Donation Auction at the discretion of the auctioneer. We encourage everyone to walk the show regularly to see what becomes available. Questions can be addressed directly to Tom Kleinschmidt at [tomkleinschmidt@comcast.net](mailto:tomkleinschmidt@comcast.net).

# NEWS FROM THE HAMSHACK

By: Jim Novak, WA9FIH

## NOVICE TWIN TRANSMITTERS: JOHNSON VIKING ADVENTURER AND KNIGHT T-50

A recent e-mail conversation with our Ham Radio station trustee Ron Grams, WB9IMR, jogged my memory about a couple of 1950s era transmitters that were aimed at the market for Novice Class licensees, beginners in amateur radio, who were limited to using Morse code only and required to upgrade to a higher class FCC license within a year.



*Johnson Viking Adventurer.*

E.F. Johnson, based in Waseca, Minnesota, offered their Viking Adventurer transmitter as a kit from the mid-1950s until the early 1960s. It was housed in a nice looking maroon and gray cabinet about 7-1/2" x 10-1/2" x 8". It covered the amateur 10, 11, 15, 20, 40 and 80 Meter bands (11 Meters had not been reassigned by the FCC to Citizens Band (CB) at that point), and used a 6AG7 oscillator and 807 power amplifier tube, plus a 5U4G rectifier. The kit sold for \$54.95. Plate input power was

50 Watts, well within the FCC-prescribed 75 Watt Novice limit. Crystal control was required for Novices back then, but Johnson also had a VFO available that could be used when the operator upgraded to General Class. A plug-in screen modulator kit using a 12AU7 and 12AX7 was also available for \$12.25.



Locally, Chicago's Allied Radio, producers of Knight kits, came out with a competitive Novice transmitter. Originally designated as the 83YX255, but which became commonly known as the T-50, it had a virtually identical design – tubes, schematic, accessory modulator and VFO as well – but, to top it off to the amazement of many, its physical size was the same as the Adventurer. And, the front panel layout perfectly mimicked that of Johnson's rig! There were some minor differences in the radios – the Adventurer was built on an aluminum chassis, while the T-50 used a copper plated steel chassis, and of course, the knob style was unique to each unit.



*Knight T-50 Transmitter.*

How did they perform? Well, as with any kit, a lot depended upon how carefully they were constructed. This could be problematic with a “newbie” who might not have much experience with electronics, much less kit building. But, this was a way to get started in Amateur Radio without a huge cash outlay. As such, the kits enabling the newcomer to focus on obtaining the best possible receiver (“if you can’t hear them you can’t work them”) and a decent antenna system.

## **HISTORY ZONE**

**An Occasional Column on Historical Items of Interest  
By David Bart**

### **REMEMBER SPUTNIK?**

Just over sixty years ago, the Soviet Union launched Sputnik, the world's first satellite and the first manmade object to reach space. Launched on October 4, 1957, Sputnik was expected to have a short lifespan because the satellite's electric batteries only would function for two weeks. However, Sputnik stayed in its elliptical low-earth orbit for three months. Sputnik burned up on January 4, 1958, while reentering Earth's atmosphere after completing 1,440 orbits and travelling a distance of about 43 million miles / 70 million kilometers.

## The Year Was 1958

The International Geophysical Year (IGY) was an international scientific project that lasted from July 1, 1957, to December 31, 1958. It was celebrated around the world with scientific programs and initiatives. Sputnik was a spectacular feat designed to coincide with the IGY. A byproduct of Soviet Premier Nikita Krushchev's quest for an intercontinental missile and the desire of Soviet scientists to design a vehicle for manned space flight, Sputnik was at once both small and spectacular.



*Logo for the International Geophysical Year.*

## A Radio in The Sky

Sputnik demonstrated the Soviet Union's technological advancement and spurred the United States into stepping up its game in the newly christened "space race." Sputnik, which means "traveling companion" in Russian, was a sphere approximately 23 inches / 58 centimeters in diameter, with four long antennas protruding from its head. It weighed 184 pounds / 83 kilograms, and included a radio beacon that transmitted a beeping sound as it orbited the earth every 98 minutes. The transmitter's beeping could be heard on the world's radio stations, and the satellite could be seen with the naked eye in the night sky as it passed overhead



*A Soviet space scientist with Sputnik before the launch. (History.com)*

News reports at the time stated that anyone with a short-wave receiver could hear the new Russian satellite as it hurtled overhead. Worldwide amateur radio organizations like the Amateur Radio Relay League (ARRL) gave instructions to their members. Radio operators sought QSL cards as a written confirmation of their one-way reception of the radio signal from Sputnik. Popular Electronics, QST, and other periodicals explained how to obtain the QSL cards and included pictures of those received.

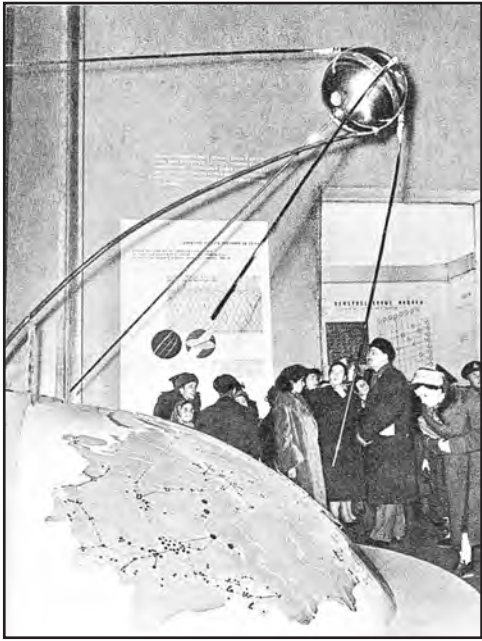

1957 SPUTNIK Space Pavilion VDNKh Exhibition - Russian postcard. (Authors' collection)

### The Radio Transmitter and Antennas

Sputnik was made of two hemispheres, each two-millimeters (mm) thick and covered with a highly polished one-mm-thick heat shield made of aluminum-magnesium-titanium AMG6T alloy. Sputnik contained the following items in its heat-resistant sphere: a radio transmitter; power supply system made out of three silver-zinc batteries; remote switch; thermal system fan; dual sequencer switch for the thermal control system; thermal control switch; and a barometric switch. Sputnik's transmitters were described as D-200 units, which were characterized as "vacuum valve-type" with a power of one watt. One transmitter operated on a frequency of 20.005 megahertz (MHz)—megacycles in 1957—and the other on 40.002 MHz. These frequencies allowed reception by amateurs using existing equipment. They also enabled a receiver set at exactly 20 or 40 MHz to produce an audio tone plus or minus the Doppler shift without ever going through zero hertz (Hz). This ensured that Sputnik's telemetry was audible throughout an entire pass without additional tuning of the receiver.

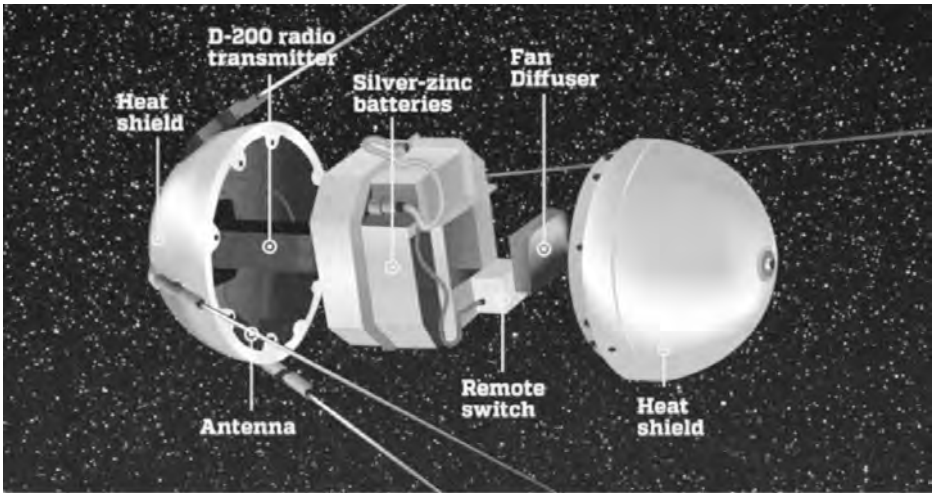

Michael Stillwell-illustrated video capture of Sputnik's components. (Popular Mechanics)

Sputnik's antennas consisted of four whips attached to the aluminum sphere through insulators that were spaced symmetrically around the circumference of the spherical casing. These elements extended at a 70-degree angle to each other and gave the satellite its iconic shape. The antenna configuration blended the need for simplicity with the space constraints of the launch vehicle and function. During launch, the antenna elements were compressed against the side of the rocket at an angle of 45 degrees and were held in place by clips and a conical shroud that protected the satellite. The antennas are described as matched pairs, one 2.4 meters and the other 2.9 meters in length. They were likely some variation of a center-fed dipole, with the longer pair radiating the 20-MHz (14-meter) signal and the shorter pair set up for 40 MHz (7.5 meters). Sputnik had no mechanism for spin-stabilization that would maintain its antennas in any particular orientation relative to a receiving station on earth. However, the antennas had an almost spherical radiation pattern, so that the satellite transmissions were made with equal power in all directions, making reception of the transmitted signal independent of the satellite's rotation.

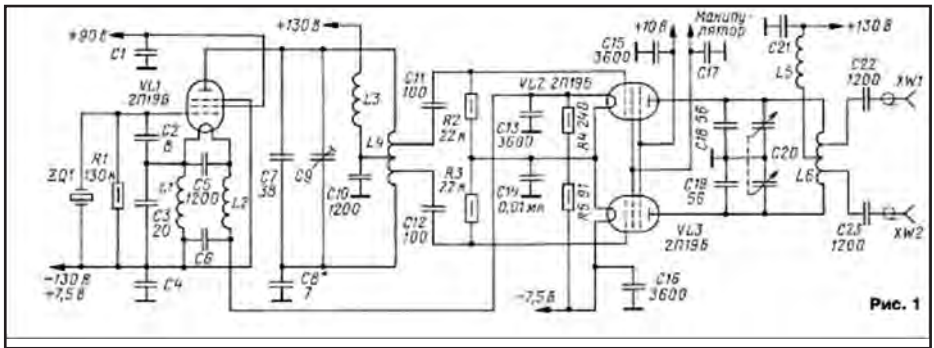

Original circuit of the Sputnik transmitter. (Radiomuseum.org)

Sputnik was filled with nitrogen at an internal pressure of 1.3 atmospheres. The power supply to the radio transmitter and the thermal control system were activated by a remote switch that was triggered by a sensor at the moment the launch vehicle and the satellite separated. The radio transmitter emitted signals lasting 0.4 seconds. If the temperature onboard the satellite ever exceeded 50 degrees Celsius or fell below zero degrees Celsius, or if the pressure inside fell below 0.35 kilograms per square centimeter, thermal and barometric switches were activated that changed the length of the radio signal transmitted by the satellite. A special fan was used to maintain normal temperature inside the satellite. The fan was activated when the interior temperature exceeded 30 degrees Celsius. If the temperature fell below 20 degrees Celsius, the fan would turn off. A dual thermal switch was responsible for turning the fan on and off.



Magazine Covers: (L) Paris Match, October 19, 1957, and (R) Time Magazine January 6, 1958.

**The Space Race**

On November 3, 1957, the Soviet Union launched a second, heavier Sputnik carrying a dog, Laika (“Barker” in Russian), providing evidence of a significantly advanced capability to use the outer-space environment. At the time, Sputnik I and II’s significance gave the Soviet Union tremendous prestige and provoked great anxiety in the United States and amongst its allies. Today, historians conclude that the artificial satellite’s biggest impact was the incredible legacy of space exploration achievements that it inspired. Sputnik is credited for instigating President John F. Kennedy’s 1961 declaration that America would put a man on the moon before then end of the decade, and with stimulating an international technology “space race” that generated spectacular accomplishments.





*1957 Sputnik commemorative items: (L) cigarette case, “4 October 1957. First in World”; (C) desk model “Space 4-X-1957 USSR First Satellite”; (R) cigarette case, “4 October 1957. Soviet Sputnik Globe.” (Authors’ collection)*

Sputnik’s launch created an international rivalry that lasted decades and sent Americans to the moon, but which ultimately gave way to cooperation and collaboration. Sixty years later, Americans and Russians not only work alongside each other, but also alongside astronauts from many other countries aboard the International Space Station.

### **Sputnik’s Enduring Fame**

The launch of Sputnik I and II occurred in late 1957 and early 1958. Yuri Gagarin became the first man in space in April 1961, followed by John Glenn in February 1962 and ultimately the astronauts of Apollo 11 who walked on the moon in July 1969. Today, young people can barely name Gagarin, Glenn, Neil Armstrong, Edwin “Buzz” Aldrin and Michael Collins. The Apollo program, Soyuz program, the moon landing, and the Apollo-Soyuz project are distant, fading memories. The International Space Station captures periodic news attention. The end of the Space Shuttle Program terminated, for the time being, America’s frequent journeys into space. Yet, Sputnik remains easily identifiable. Its heritage can be seen in the enduring popularity of Sputnik collectibles. Sputnik’s shape and sounds continue to appear in our pop culture.

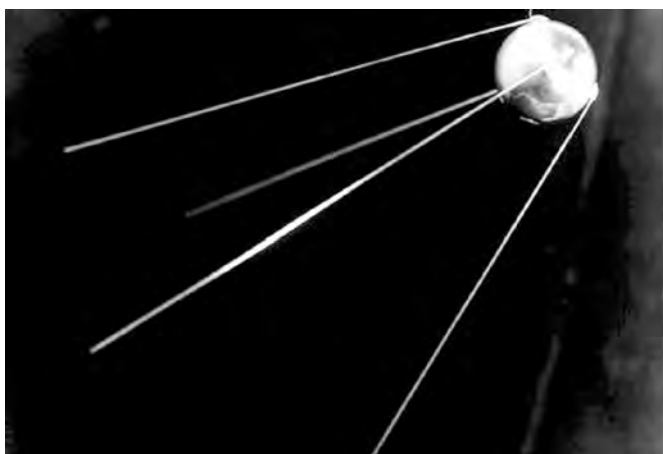

*Sputnik With Antennas Fully Extended (Courtesy NASA).*

Perhaps today we need another Sputnik moment to inspire the nation and the world about space, radio, and the quest for science in the way that a little satellite did 60 years ago.

### Sputnik's Visit to Radiofest

In 2005, ARCI had the rare opportunity of seeing an actual Sputnik I. That year, the *Radiofest* contest director Bob Drake brought a very special surprise. Bob was able to borrow one of the original Russian Sputnik I satellites, and placed it on display in the contest room. This Sputnik satellite was one of about twenty, of which ten were eventually placed into orbit beginning with the first launch on October 4, 1957. The surplus Sputniks were sold by the Russian government, and this one belonged to a private collector who opted to remain undisclosed. What a treat for all the *Radiofest* attendees!!!



## BUSINESS CARD ADS

We invite all of our members to scan and send in your business card to be included in *ARCI NEWS*. For \$80 your card will appear in the next 6 issues! Your card will be seen by approximately 400 people per issue and up to 1,000 people at *Radiofest* where we make additional copies of *ARCI NEWS* available at no charge. If interested, please scan your card and send it to [jbart1964@gmail.com](mailto:jbart1964@gmail.com) and mail a check for \$80 to Rudy Hecker, ARCI Treasurer, 127 Weymouth Court, Schaumburg, IL 60193. Thank you all for your continued support of ARCI!!!



**Just Radios**  
Capacitors & Resistors for Tube Radios

David and Babylyn Cantelon  
6 Ferncrest Gate, Scarborough  
Ontario, Canada, M1W 1C2

[www.justradios.com](http://www.justradios.com)  
[justradios@yahoo.com](mailto:justradios@yahoo.com)  
(416) 502-9128



**BOHEMIAN BILL**  
REPAIRS • BUYS • SELLS

Old Radios  
Record Players, Parts, Tubes  
Over 50 Years Experience!  
Free Estimates

**608-253-9855**  
100's of Radios for Sale



## PAID ADVERTISING

THE VINTAGE HAM RADIO OPERATORS AND COLLECTORS  
EVENT OF THE YEAR

### **MIDWEST CLASSIC RADIO HAMBOREE**

The 2018 event will be held as part of the  
SIX METER CLUB OF CHICAGO  
and the  
ANTIQUA RADIO CLUB OF ILLINOIS'  
HAM RADIO AND ELECTRONIC FLEA MARKET

**SUNDAY, JUNE 17, 2018**

AT THE  
DU PAGE COUNTY FAIRGROUNDS  
WHEATON ILLINOIS

\*\*\*\*\*

<http://MCRN3885.net/>  
(MCRN3885.net)

### **Wisconsin Antique Radio Club, Inc.**

[www.warci.org](http://www.warci.org)

We welcome you to our upcoming meets:

**July 8, 2018 ~ 8am-11am**

The Terminal, 5917 S Howell  
Milwaukee, WI 53207

Doors open at 8AM. The flea market starts at 8AM,  
announcements are held at 10:30 AM followed by the  
donation auction and free pizza!

Swap meet spaces are \$7 for WARCI members and  
\$10 for non-members.

Swap meet spaces are \$7 for WARCI members and  
\$10 for non-members.

More information is available at [www.warci.org](http://www.warci.org)

**Our 33rd annual**  
VINTAGE  
**ELECTRONICS**  
E · X · P · O

**EXTRAVAGANZA '18**  
**July 12, 13, 14, 2018**

Powered by the  
**MICHIGAN ANTIQUE  
RADIO CLUB**

**THIS YEAR'S THEME:**  
**FISHER and H.H. SCOTT**



Fisher 400



H.H. Scott 1700

At the  
**KALAMAZOO EXPO CENTER**  
2900 Lake Street, Kalamazoo, MI

For show information, contact:

**Mark Goodwin**  
9225 Moon Road  
Saline, MI 48176  
(734) 316 2803

Email: [mrkgoodwin@comcast.net](mailto:mrkgoodwin@comcast.net)

Alternate contact: Mark Oppat  
(734) 207-2346 [moppat@comcast.net](mailto:moppat@comcast.net)

**[www.thevee.org](http://www.thevee.org)**

[www.facebook.com/michiganantiqueradio](http://www.facebook.com/michiganantiqueradio)  
[www.michiganantiqueradio.org](http://www.michiganantiqueradio.org)



# AWA CONVENTION & SELLERS MARKETS

August 14 – 18, 2018

## MARK YOUR CALENDARS FOR AN EXCITING CONFERENCE

The 2018 convention will be held at the *RIT Conference Center*. Take Exit 46 of the New York State thruway (I-90), to I-390 North, to NY 253 West, and then NY 15 South. The convention dual themes this year are "*Spark Era*" and "*Firsts – First of a Kind or First of a Series*".

*Visit the Antique Wireless Museum during a special free open house on Wednesday.*

There will be approximately 17 *Presentations* covering every area of communications history. Enjoy shopping for that special buy in the *Flea Market* and in the *Book Fair*. The exhibits shown at the *Old Equipment Contest* will offer rare historical insights. Finally, you'll never go hungry at the AWA Convention! From the Welcome Dinner on Tuesday night to the Awards Banquet on Friday, enjoy the Special *Food Events* of the Convention.

### 2018 AWA OVERALL CONVENTION SCHEDULE

#### TUESDAY, AUGUST 14, 2018

1:00 pm Registration Desk Opens  
7:00 pm Welcome Dinner

9:15 am – 12:00 Programs  
12:00 – 1:00 pm Lunch  
12:00 pm Special Guests Luncheon  
1:00 – 5:15 pm Programs  
5:30 pm Buffet Dinner Social Hour  
6:00 pm Buffet Dinner with Collins  
Collectors Association Presentation  
8:00 pm Midnight Restorations  
10:00 pm Movie

#### WEDNESDAY, AUGUST 15, 2018

9:00 am Registration Desk Opens  
9:15 am – 12:00 Programs  
12:00 – 1:00 pm Lunch on your own  
1:00 – 5:15 pm Programs  
5:00 – 8:00 pm Antique Wireless Museum Open  
8:00 pm Ice Cream Social at the RIT Inn

#### FRIDAY, AUGUST 17, 2018

9:00 am Registration Desk Opens  
9:00 am Book Fair Opens  
9:15 am AWA Member's Meeting  
10:45 am – 12:00 Program  
12:00 – 1:00 pm Lunch Break with Contest Viewing  
1:00 – 5:15 pm Programs  
4:00 – 5:30 pm Register Auction Items for sale  
6:00 pm Banquet Social Hour  
7:00 pm 2018 AWA Banquet  
(appropriate dress is requested)  
Contest Viewing  
After Banquet

#### THURSDAY, AUGUST 16, 2018

6:00 am Flea Market officially opens and remains open continuously  
*NOTE: Outside sales are strictly private transactions. Sellers remain responsible for taxes and all legal aspects of these transactions. Buyers and Sellers are reminded that neither the AWA nor RIT are parties to any of these transactions.*  
9:00 am Registration Desk Opens  
9:00 am Book Fair Opens

#### SATURDAY, AUGUST 18, 2018

7:00 – 8:00 am Equipment Auction Preview  
8:00 am - end Equipment Auction  
No Seller Payouts until one hour after the auction ends.

# CLUBBING AROUND

## MIDWEST CLASSIC RADIO HAMBOREE

The Midwest Classic Radio Net will have its annual Hamboree on JUNE 17, 2018 (rain or shine) during the ARCI-SIX METER CLUB Hamfest. This is the vintage ham radio operators and collectors event of the year. This is a meet dedicated to vintage ham and communications equipment, and it is also a social gathering of those who are interested in the vintage gear. MCRN is a gathering of hams that operate “boat anchor” equipment on a weekly 3885 kHz AM net. See <http://hamboree.tripod.com/> or contact Harry Blesy at [n9cqx@hotmail.com](mailto:n9cqx@hotmail.com).

## ANTIQUÉ WIRELESS ASSOCIATION

The Antique Wireless Association will hold its Annual Convention on Aug. 14-18, 2018 in Rochester, New York at the RIT Inn and Conference Center (see separate ad). The dual themes this year are: SPARK ERA and FIRSTS – FIRST OF A KIND OR FIRST OF A SERIES. Come see the new museum displays and join us in 5 days of activities with more than 17 presentations. This is the best historical conference in the country for people interested in the history of electronic communications. The AWA, our national affiliate, publishes the AWA Journal and the AWA Review. Dues are \$35 per year. Information can be found at [www.antiquewireless.org](http://www.antiquewireless.org).

## WISCONSIN ANTIQUE RADIO CLUB, INC.

The next WARCI meeting will take place July 8, 2018 at the Terminal, located at 5917 South Howell Street in Milwaukee near the airport from 8AM-11AM. For information about the club, see [www.warci.org](http://www.warci.org).

## NORTHLAND ANTIQUE RADIO CLUB

NARC will hold its annual meeting and mini swap meet in September 2018. For information about the event, please see <http://www.northlandantiqueradioclub.com/index.shtml>.

## MICHIGAN ANTIQUE RADIO CLUB

MARC's Vintage Electronics Expo Extravaganza 2018 will be held July 12-14 at the Kalamazoo Expo Center in Kalamazoo, Michigan. This is one of the top shows of the summer. For more information see <http://michiganantiqueradio.org>.

## INDIANA HISTORICAL RADIO SOCIETY

The IHRS Summer Meet will be Saturday, August 11, 2018 from 8-11 am at the Cool Creek Park Nature Center in Carmel, Indiana (East of US 31 and North of 151st Street in Carmel). The IHRS Fall Foliage Meet will be October 14, 2017 from 8am to noon at the Riley Park Shelter, Greenfield, Indiana (one block north of US40 on Apple Street). For more information see [www.indianahistoricalradio.org](http://www.indianahistoricalradio.org).





# ARCI NEWS

Antique Radio Club of Illinois

PO Box 1139

LaGrange Park, IL 60526